

STACKE Info

BRIEF UP TO DATE INFORMATION ON NEW PRODUCTS

EUROLINE SAFES

Type **EL 180.975 CD**, resistance grade **CEN V CD**

In accordance with Euronorm 1142-1, VdS, ECB•S certified



The large, double-winged safe, especially for safe deposit boxes

Capacity: 4 rows of deposit boxes side by side; total usable height: 1700 mm

Optimal efficiency ratio of required space : usable space

This means getting more space and having more boxes, combined with optimal security, core drill (CD) protection, a safe wall thickness of only 75 mm and, therefore, relatively favourable weight

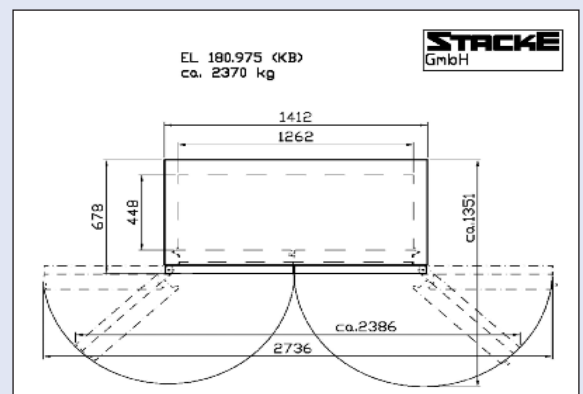

EUROLINE SAFES

Type EL 180.975 CD, resistance grade CEN V CD

Comes with tested core drill protection and - in the basic version - a mechanical lock system according to VdS, 1 x KL + 1 x CL (see photo), optionally a fully electronic lock with 1 user panel and 2 ECLs electronic code locks (also see, all versions in the Euroline prospectus), optionally door hinges (see photo), continuously adjustable.



Structure

- 4-row safe deposit box insert, for combination of box heights measuring 50 / 75 / 100 / 150 / 200 / 225 / 300 mm
- Limited integration possible of: Double-width boxes (see photo on the cover page)
- Available height: 68 x 25 (grid) = 1700 mm

Technical specifications

Outside dimensions:	1875 x 1412 x 678* mm (hwxwd) * plus fittings
Inside dimensions:	1725 x 1262 x 448 mm
Weight, empty, approx.:	2370 kg
Volume:	975 l